



EM-125FTYII-N

New Product 新制品

1 General Description

品格介绍

Application : Conference Phone, Voice Recorder, Home surveillance camera, Hearing Aid, Car Kit, Headphone, etc...

用途: 会议电话机, 录音机, 住宅安全监通话机, 助听器, 耳机汽车通讯器材, 类似等等...

2 Appearance and Mechanical Dimension

外观. 尺寸图形

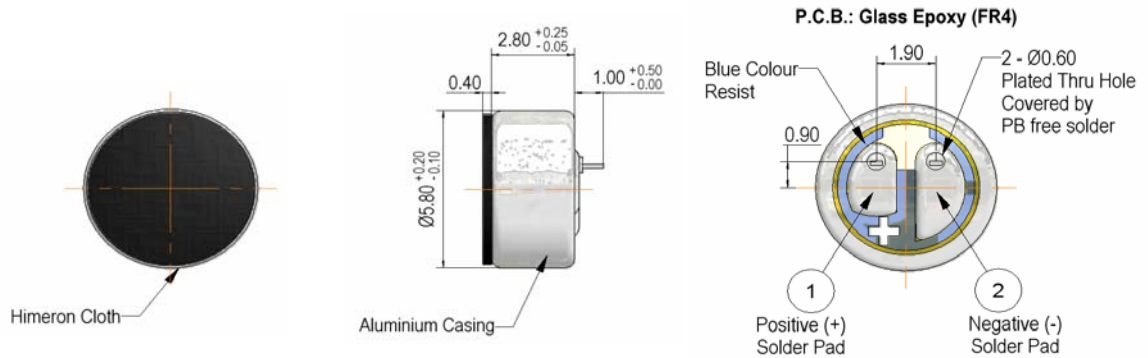

3 Specifications

规格

- 2-1 Directivity (方向特性) : Omni-Directional (全向)
- 2-2 Sensitivity at 1kHz (灵敏度) : $-43.0 \pm 3.0\text{dB}$
(ref. 0dB=1V/Pa)
- 2-3 Operational Setting (操作设立集) : $R_L=2.0\text{k}\Omega$ $V_{cc}=3.0\text{V}$
- 2-4 Impedance (阻抗) : $1.6\text{k}\Omega$
- 2-5 Current Consumption (电流消耗) : Max. $400\mu\text{A}$
- 2-6 Built-in Capacitor (嵌入电容) : J $\rightarrow 10\text{pF}$, K $\rightarrow 33\text{pF}$
[N $\rightarrow (10\text{pF} + 33\text{pF})$]
- 2-7 Signal Noise Ratio (信噪比) : More than 58dB
- 2-8 Sound Pressure Level (音压) : Max. 115dB SPL

4 Circuit Diagram

集成电路

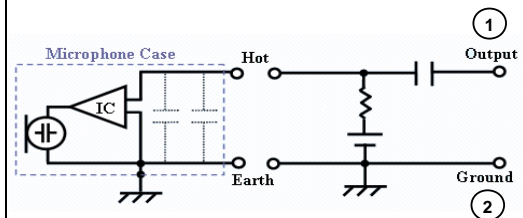

*Note (指明)

EM-125FTYII-N: Built-in Capacitors (嵌入电容)
N: $10\text{pF} + 33\text{pF}$

5 Frequency Response

频率特性曲线

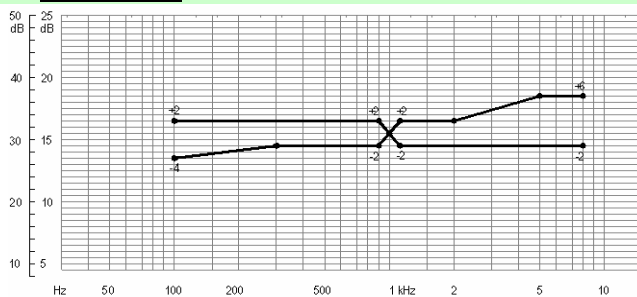

6 Polar Pattern

极线结构

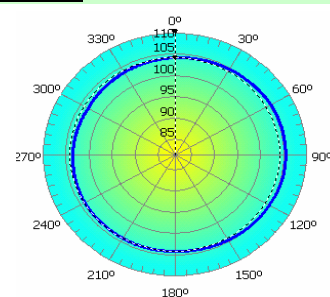

PRIMO MICROPHONES SINGAPORE (PTE) LTD

171, Kallang Way, #02-05/06. Singapore 349250.

TEL: (65) 6747 3586 FAX: (65) 6744 3597

E-mail: pmsls@singnet.com.sg

Website: <http://www.primo.com.sg>

PRIMO MICROPHONES (HK) CO., LTD

Unit No: 1705, Level 17, Tower II

Grand Central Plaza, Shatin N.T Hong Kong

TEL: (852) 21449651 / 21449756 FAX: (852) 21449836

E-mail: pmhk8988@netvigator.com