



EM-80FYIIPX7-N

1 General Description 品格介绍

Application : Conference Phone, Voice Recorder, Home Surveillance Camera, Hearing Aid, Car Kit, Headphone, etc...
用途: 会议电话机, 录音机, 住宅安全监通话机, 助听器, 耳机汽车通讯器材, 类似等等...

2 Appearance and Mechanical Dimension 外观. 尺寸图形

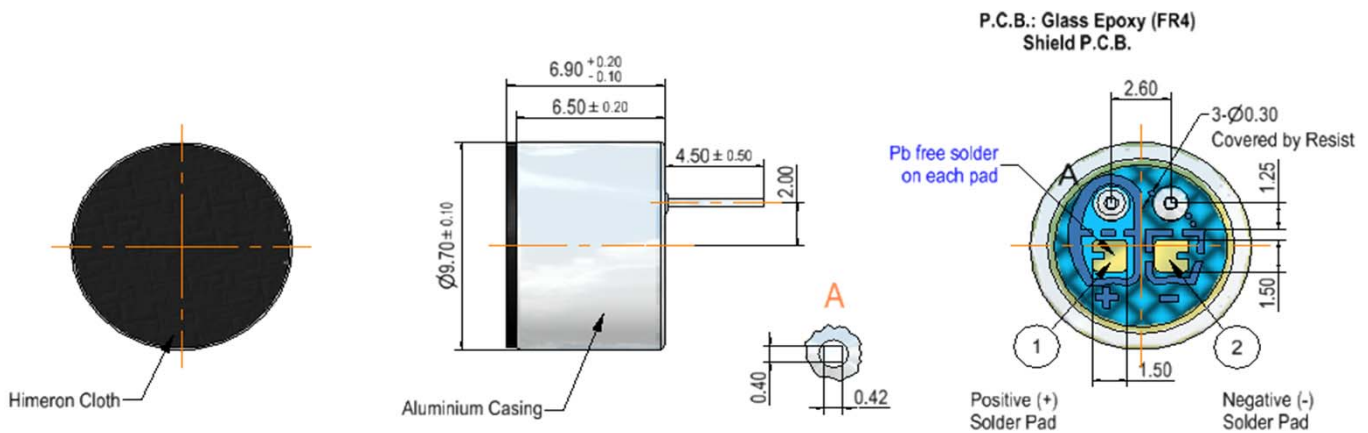

3 Specifications 规格

- | | |
|---------------------------------------------------|---------------------------------------------|
| 2-1 Directivity (方向特性) | : Omni-Directional (全向) |
| 2-2 Sensitivity at 1kHz (灵敏度)
(ref. 0dB=1V/Pa) | : -40.0 ± 3.0dB |
| 2-3 Operational Setting (操作设立集) | : RL=2kΩ VCC=1.5V |
| 2-4 Impedance (阻抗) | : 2KΩ ± 30% at 1KHz |
| 2-5 Current Consumption (电流消耗) | : Max. 350μA |
| 2-6 Built-in Capacitor (嵌入电容) | : J → 10pF, K → 33pF
[N → (10pF + 33pF)] |
| 2-7 Signal Noise Ratio (信噪比) | : More than 60dB |
| 2-8 Sound Pressure Level (音压) | : Max. 120dB SPL |

4 Circuit Diagram 集成电路

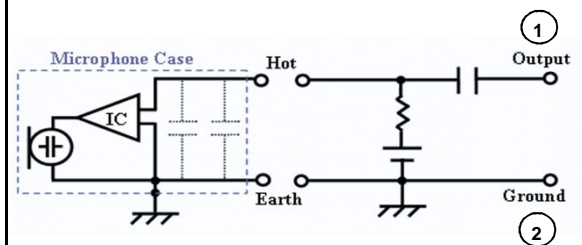

*Note (指明)

EM-80FYIIPX7-N: Built-in Capacitors (嵌入电容)
N: 10pF + 33pF

5 Frequency Response 频率特性曲线

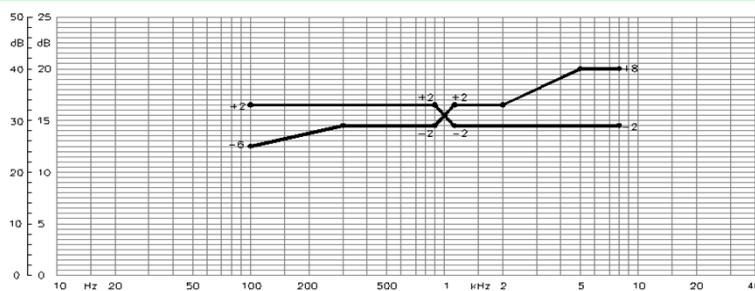

6 Polar Pattern 极线结构

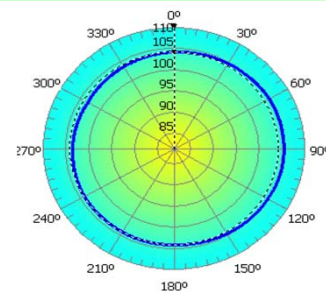

PRIMO MICROPHONES SINGAPORE (PTE) LTD

171, Kallang Way, #02-05/06. Singapore 349250.
TEL: (65) 6747 3586 FAX: (65) 6744 3597
E-mail: pmsls@singnet.com.sg
Website: http://www.primo.com.sg

PRIMO MICROPHONES (HK) CO., LTD

Unit No: 1705, Level 17, Tower II
Grand Central Plaza, Shatin N.T Hong Kong
TEL: (852) 21449651 / 21449756 FAX: (852) 21449836
E-mail: pmhk8988@netvigator.com